

Smarter ID, Smarter Insights: RFID with Sensor Data

RAIN RFID

Logopak is a member of:



RFID solutions
by Logopak

LOGOPAK
The Perfect Labelling System.

Logopak Systeme GmbH & Co. KG
Dorfstraße 40–42 · D-24628 Hartenholm
Tel: +49 (0) 4195 9975-0 · Fax: +49 (0) 4195 1265
www.logopak.com



Enabling optimal product identification
and supply chain transparency.

Optimise Your Logistics with RAIN RFID.

The RAIN RFID technology enables seamless tracking, automation, and efficiency in logistics and intralogistics. Whether for pallets, containers, products, or raw materials, Logopak provides tailored solutions to enhance visibility, accuracy, and operational efficiency. Benefit from real-time data and robust identification even in the most challenging environments.

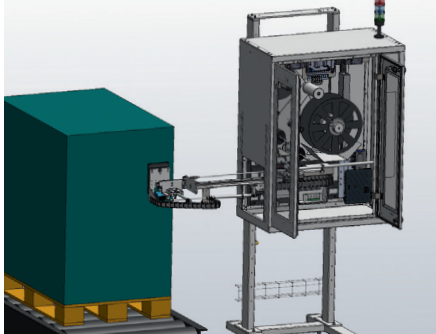

Pallet Labeling with RFID

Benefits:

- » Separate barcode verification independent of RFID function
- » Software-controlled selection between RFID tag or just a barcode label
- » Selection of tag position (Pallet side/front/rear)
- » Reliable tracking even for water/metal-based products

Use Case:

All pallet types, internal logistics, supply chain

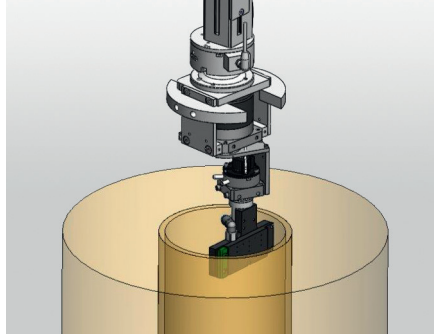

Internal Tagging of Cores

Benefits:

- » Permanent product ID that stays with the product
- » Enables automated tracking & handling
- » Usable throughout the supply chain from manufacturer to user
- » Readable even without line-of-sight

Use Case:

Products on reels (packaging materials, textiles, plastic foils)

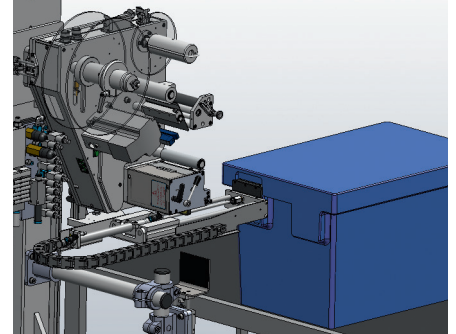

RFID for Small Load Carriers (KLTs)

Benefits:

- » VDA-compliant RFID tracking
- » Faulty tags automatically removed
- » Easy to integrate in industrial environments

Use Case:

Internal logistics, supply chain

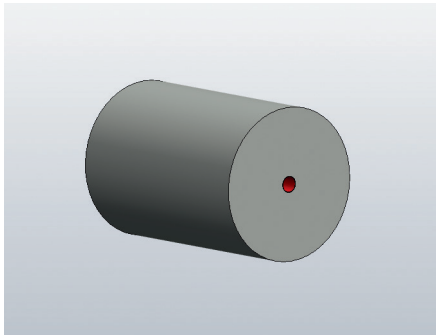

RFID for Raw Materials (Paper & Pulp)

Benefits:

- » Real-time tracking for different product qualities and production flows
- » Locate specific rolls in the warehouse without barcode scanning
- » Identification even when rotated or without line of sight
- » High reading accuracy (99.9%)
- » Improved tracking & quality control

Use Case:

Internal logistics, supply chain, quality control

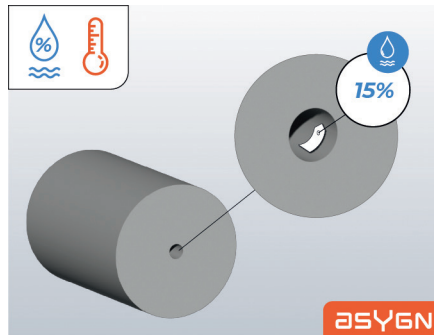

Sensor: Humidity Monitoring

Benefits:

- » Real-time data for proactive action against humidity fluctuations
- » Enables protection against moisture damage to sensitive materials
- » Supports prevention of mold formation and product losses
- » Integration into existing RFID infrastructure possible

Use Case:

Pharmaceuticals, healthcare, perishable goods storage, (paper, wood, etc.), asset tracking

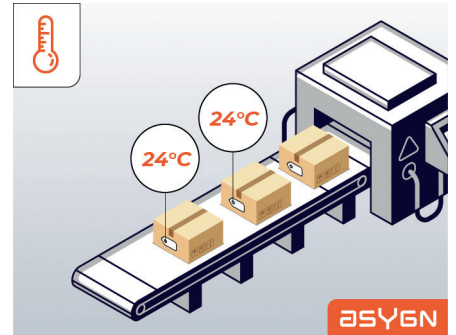

Sensor: Temperature Monitoring

Benefits:

- » Real-time temperature tracking with battery-free RFID tags
- » Supports the assurance of product integrity during transport & storage
- » Seamless integration into Logopak labeling processes

Use Case:

Cold chain logistics, food, pharmaceuticals, healthcare, asset tracking

Please note:

Red benefits apply to both sensors!